

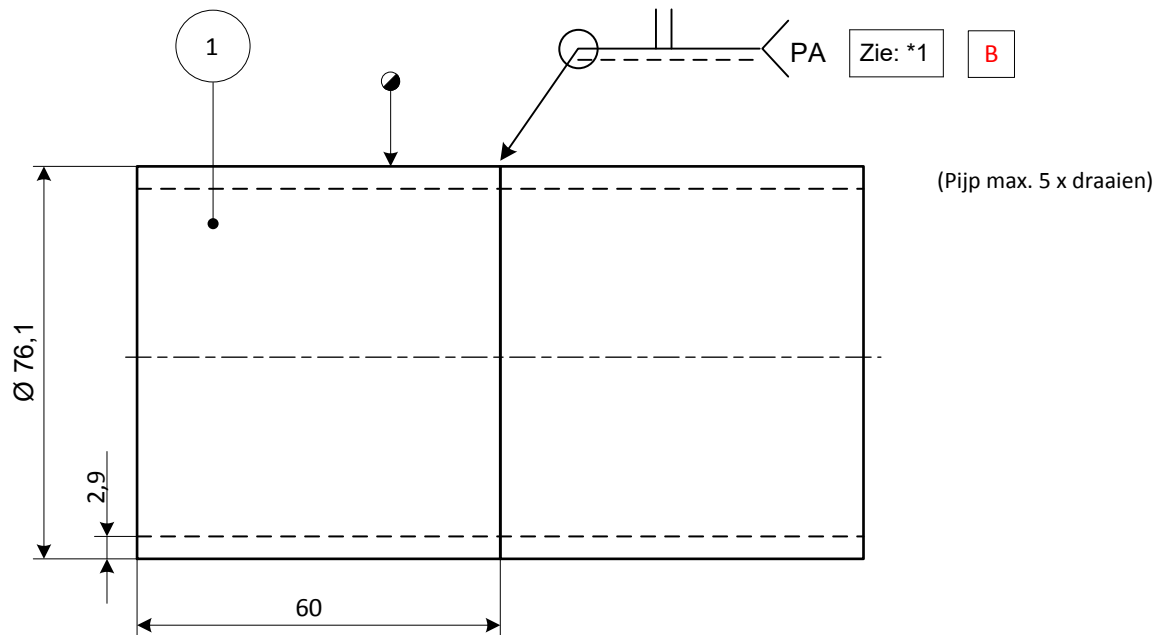

*1 = Doorlassing vereist.

1	2	Pijp	48,3 x 2,9 – 60	S235
Stuk nr.	Aantal	Benaming	Afmetingen	Materiaal soort
	Lasproces:		Beoordeling:	Nederlands Instituut voor Lastechniek Tel: 088 – 0187000 www.nil.nl
	141		Visueel en maten	
	Schaal: niet op schaal		Getekend: Examencomm. HVO	
	Maateenheid: mm		Datum: 28 – 05 – 2014	
Max. werktijd: 25 min.		● = Kandidaat nr.		
Werkstuk nr. 410 – Inst.	Niveau: TIG-1 – St - Pijp	Benaming: PIJP – PIJPLASVERBINDING		Rev: Sep. 2017
				A 4

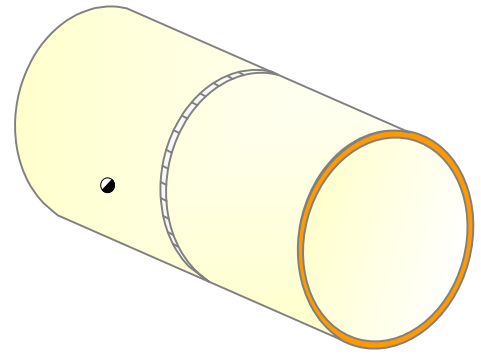

*1 = Doorlassing vereist.

1	2	Pijp	76,1 x 2,9 – 60	S235
Stuk nr.	Aantal	Benaming	Afmetingen	Materiaalsoort
	Lasproces:		Beoordeling:	Nederlands Instituut voor Lastechniek Tel: 088 – 0187000 www.nil.nl
	141		Visueel en maten	
	Schaal: niet op schaal		Getekend: Examencomm. HVO	
	Maateenheid: mm		Datum: 28 – 05 – 2014	
Max. werktijd: 30 min.		● = Kandidaat nr.		
Werkstuk nr. 411 – Inst.	Niveau: TIG-1 – St - Pijp	Benaming: PIJP – PIJPLASVERBINDING		Rev: Sep., 2017
				A 4

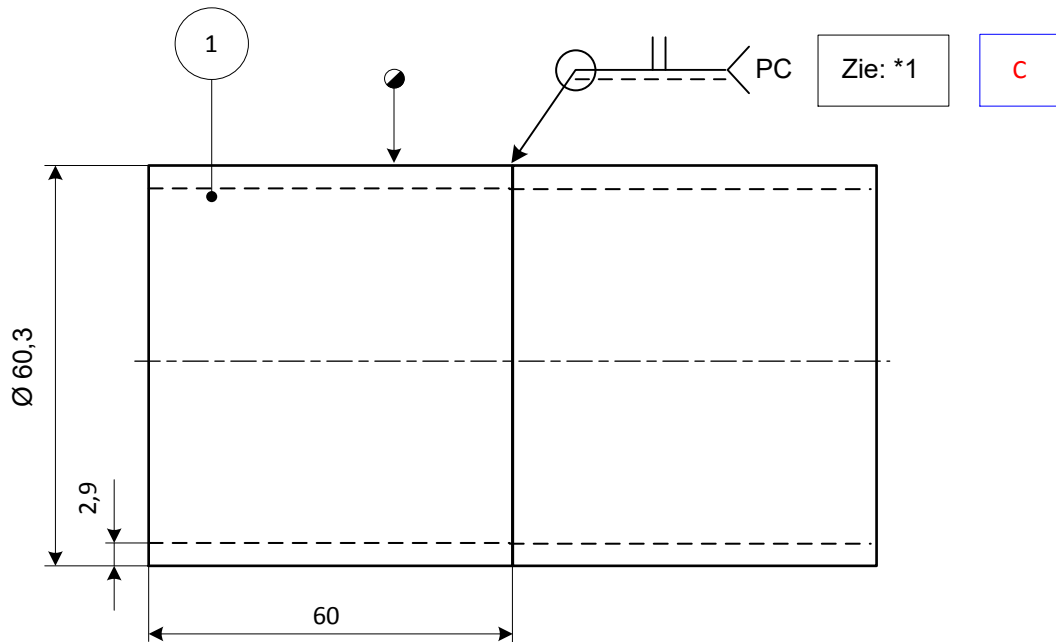
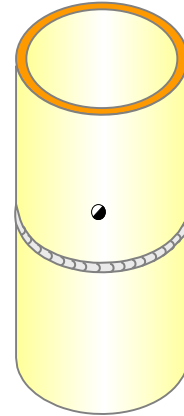

*1 = Doorlassing vereist.

1	2	Pijp	60,3 x 2,9 – 60	S235
Stuk nr	Aantal.	Benaming	Afmetingen	Materiaal soort
	Lasproces:		Beoordeling:	Nederlands Instituut voor Lastechniek Tel: 088 – 0187000 www. nil.nl
	141		Visueel en maten	
	Schaal: niet op schaal		Getekend: Examencomm. HVO	
	Maateenheid: mm		Datum: 28 – 05 – 2014	
Max. werktijd: 30 min		☉ = Kandidaat nr.		
Werkstuk nr. 412 – Inst.	Niveau: TIG-1 – St - Pijp	Benaming: PIJP – PIJPLASVERBINDING		Rev: Sep. 2017
				A 4

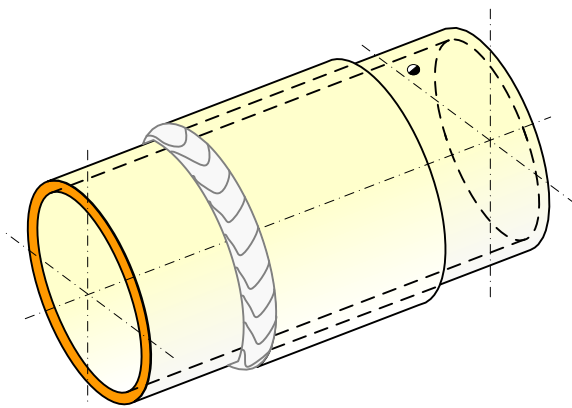

PB - Horizontaal

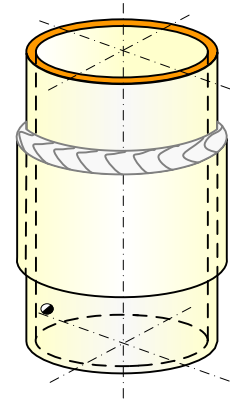

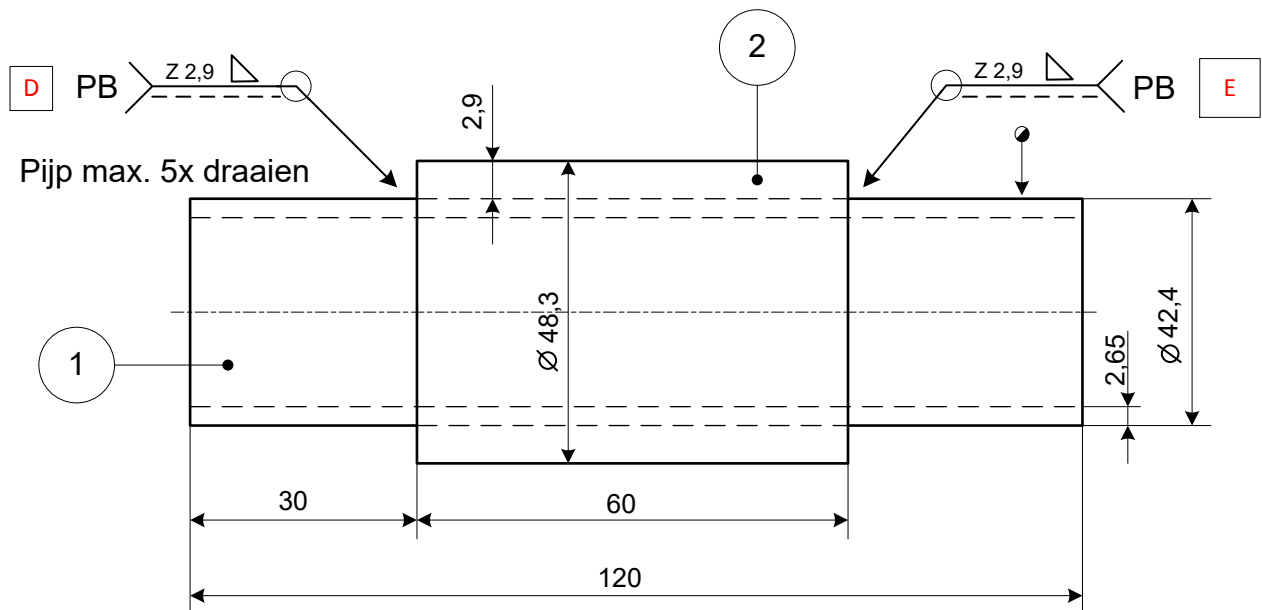

PB - Vertikaal

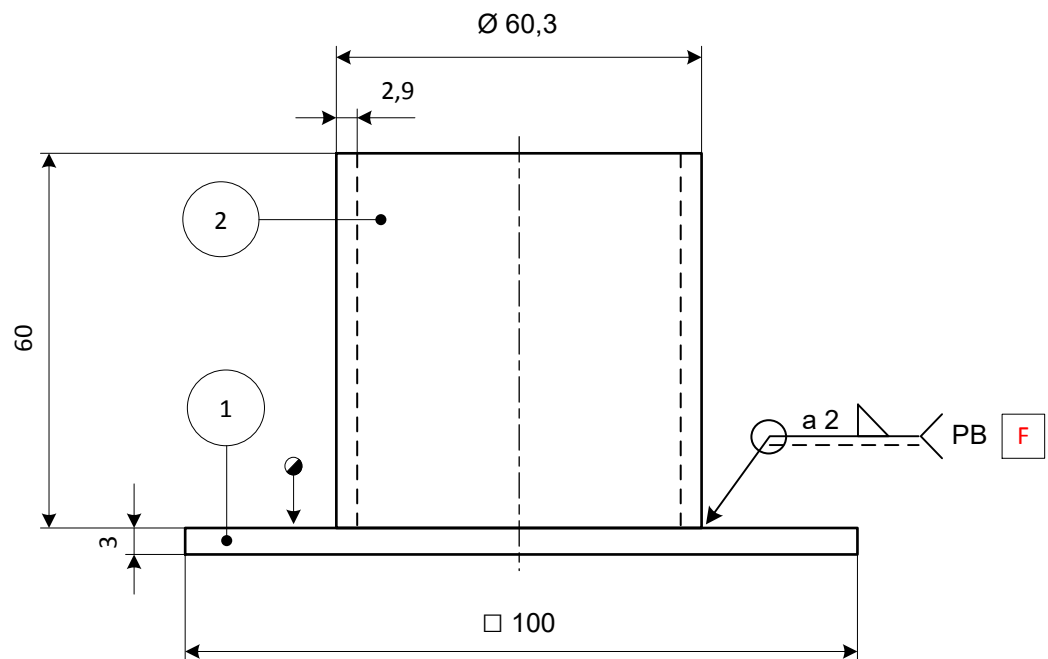
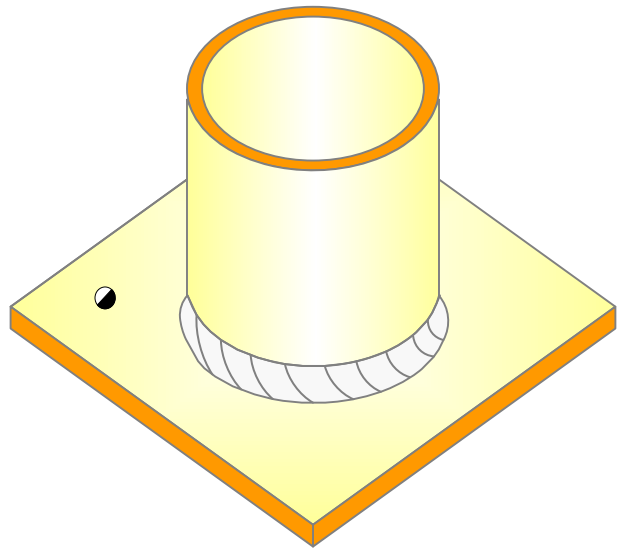

Opm. 1 cm voor het einde van de tweede las het werkstuk af laten koelen

2	1	Pijp	48,3 x 2,9 – 60	S235
1	1	Pijp	42,4 x 2,65 - 120	S235
Stuk nr.	Aantal	Benaming	Afmetingen	Materiaalsoort
	Lasproces:		Beoordeling:	Nederlands Instituut voor Lastechniek Tel:088 – 0187000 www.nil.nl
	141		Visueel en maten	
	Schaal: niet op schaal		Getekend: Examencomm. HVO	
	Maateenheid: mm		Datum: 28 – 05 – 2014	
Max. werktijd: 45 min		☉ = Kandidaat nr.		
Werkstuk nr. 413 – Inst.	Niveau: TIG-1 – St - Pijp	Benaming: PIJP – PIJPLASVERBINDING		Rev: Sep. 2017
				A 4



2	1	Pijp	60,3 x 2,9 – 60	S235
1	1	Plaat	100 x 100 x 3	S235
Stuk nr.	Aantal	Benaming	Afmetingen	Materiaal­soort
	Lasproces:		Beoordeling:	Nederlands Instituut voor Lastechniek Tel:088 – 0187000 www. nil.nl
	141		Visueel en maten	
	Schaal: niet op schaal		Getekend: Examencomm. HVO	
	Maateenheid: mm		Datum: 28 – 05 – 2014	
Max. werktijd: 20 min		● = Kandidaat nr.		
Werkstuk nr. 414 – Inst.	Niveau: TIG-1 – St - Pijp	Benaming: PIJP – PLAATLASVERBINDING		Rev: Sep. 2017
				A 4