

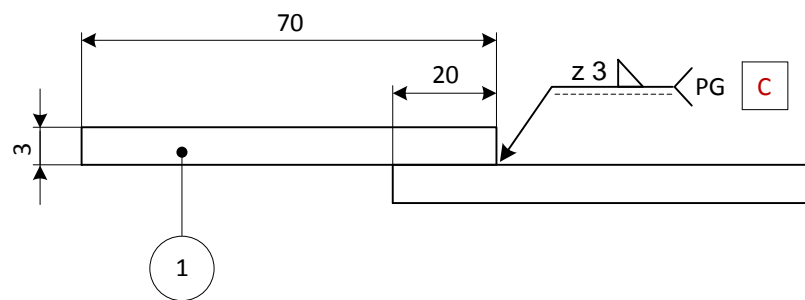

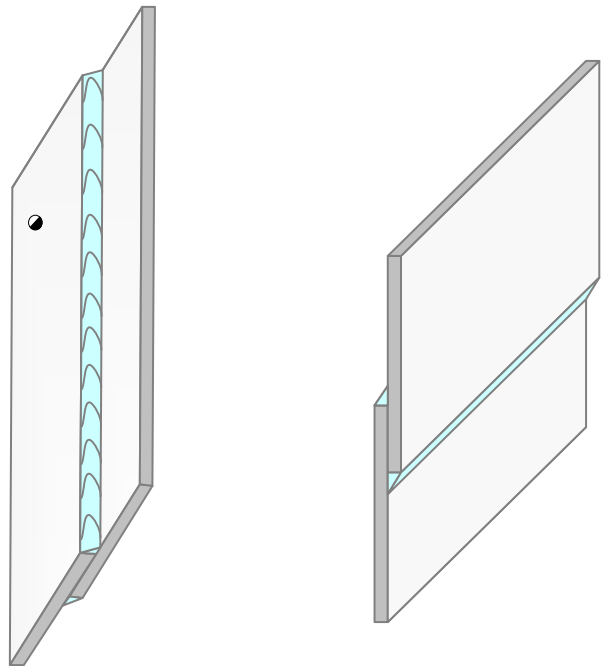

2	2	Plaat	30 x 5 – 250	RVS 304 - 316
1	1	Plaat	80 x 5 – 250	RVS 304 - 316
Stuk nr.	Aantal	Benaming	Afmetingen	Materiaal-soort
	Lasproces:		Beoordeling:	
	135		Visueel en maten	
	Schaal: niet op schaal		Getekend: Examencomm. HVO	
	Maateenheid: mm		Datum: 24 – 10 – 2014	
Max. werktijd: 30 min.		● = Kandidaat nr.		Nederlands Instituut voor Lastechniek Tel: 088 - 0187000 www. nil.nl
Werkstuk nr. 360 – RVS	Niveau: MAG-2 - RVS	Benaming: KRUISSTUK		
				A 4

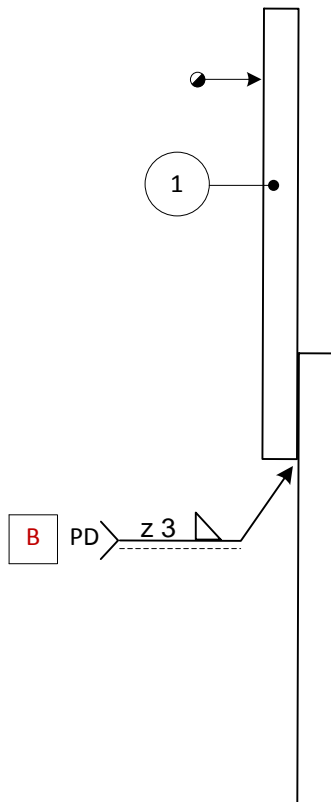

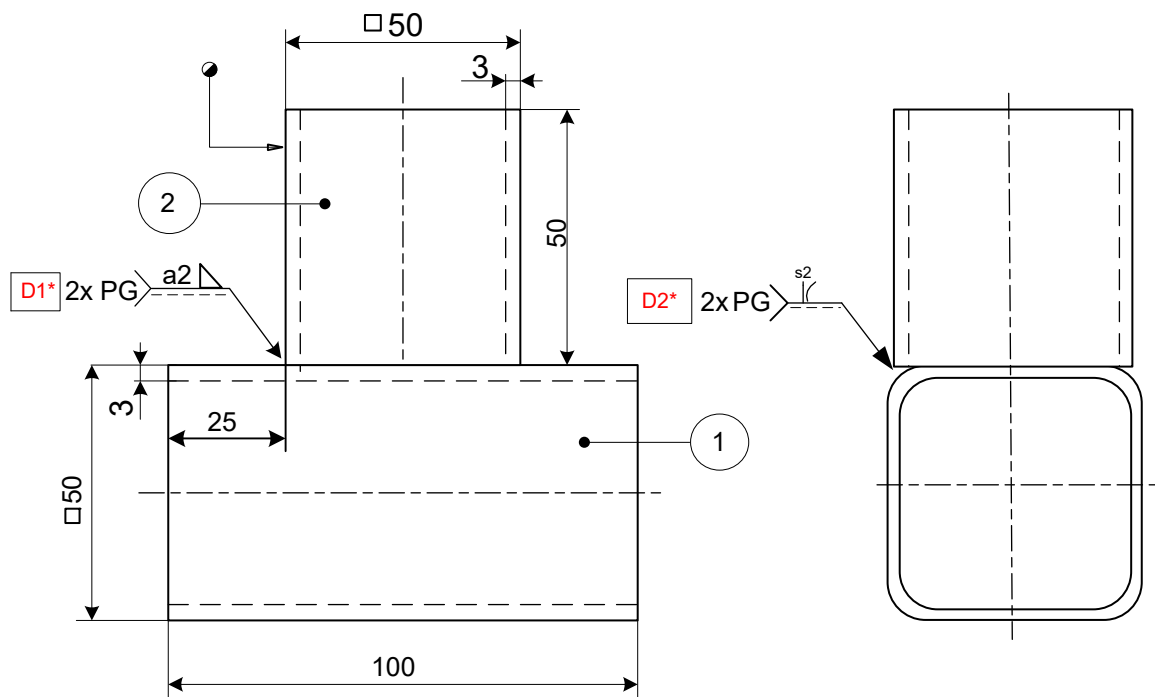
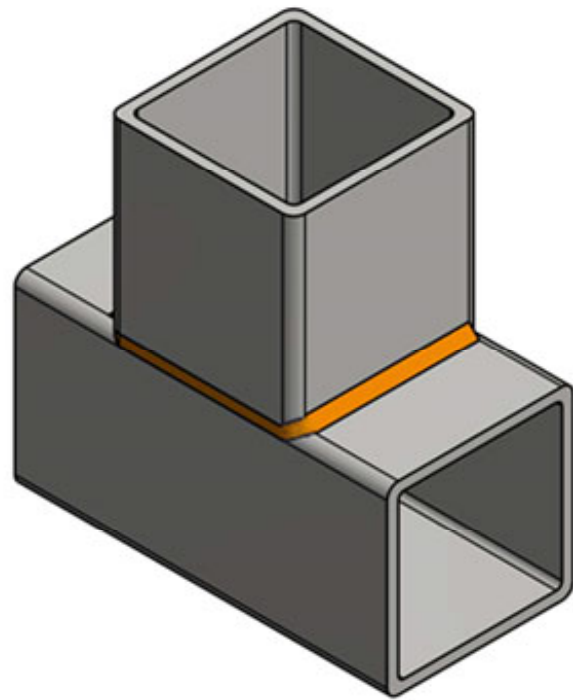

1	2	Plaat	70 x 3 – 250	RVS 304 - 316
Stuk nr	Aantal	Benaming	Afmetingen	Materiaal­soort
	Lasproces:		Beoordeling:	Nederlands Instituut voor Lastechniek Tel: 088 – 0187000 www. nil.nl
	135		Visueel en maten	
	Schaal: niet op schaal		Getekend: Examencomm. HVO	
	Maateenheid: mm		Datum: 28 – 05 – 2014	
Max. werktijd: 20 min.		● = Kandidaat nr.		
Werkstuk nr. 361–362 - RVS	Niveau: MAG-2 - RVS	Benaming: OVERLAPLASVERBINDING		Rev: Mei 2017
				A 4

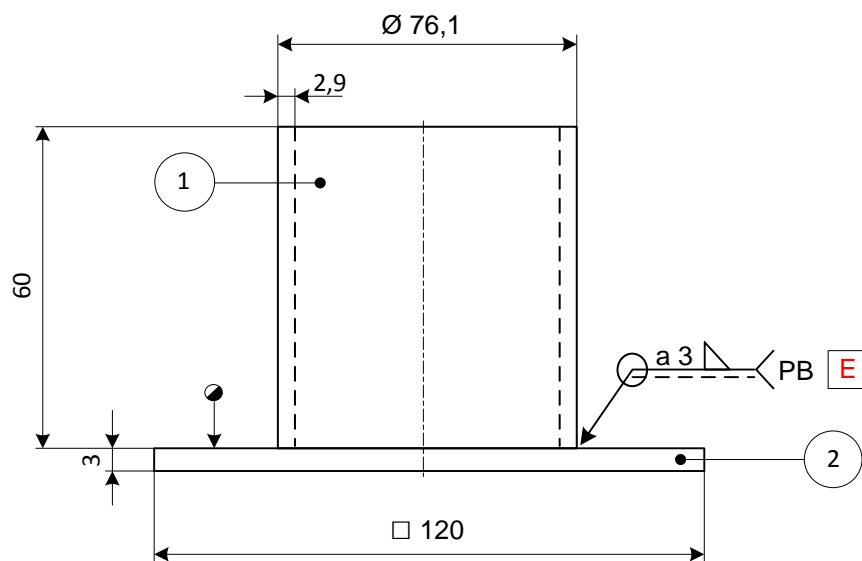
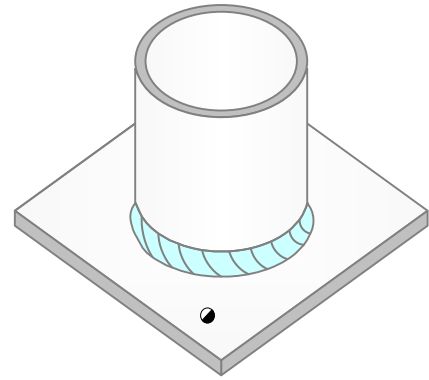

* Lassen D1 en D2 dienen vloeiend in elkaar over te lopen

2	1	Koker	50 x 50 x 3 – 50	RVS 304 - 316
1	1	Koker	50 x 50 x 3 – 100	RVS 304 - 316
Stuk nr.	Aantal	Benaming	Afmetingen	Materiaalstype
	Lasproces:		Beoordeling:	Nederlands Instituut voor Lastechniek Tel: 088 – 0187000 www.nil.nl
	135		Visueel en maten	
	Schaal: niet op schaal		Getekend: Examencomm. HVO	
	Maateenheid: mm		Datum: 23 – 09 – 2014	
Max. werktijd: 20 min.		☉ = Kandidaat nr.		
Werkstuk nr. 363 – RVS	Niveau: MAG-2 - RVS	Benaming: KOKER – KOKERLASVERBINDING		Rev: Sept. 2020
				A 4



2	1	Plaat	120 x 3 - 120	RVS 304 - 316
1	1	Pijp	76,1 x 2,6 - 60	RVS 304 - 316
Stuk nr.	Aantal.	Benaming	Afmetingen	Materiaalsoort
	Lasproces:		Beoordeling:	Nederlands Instituut voor Lastechniek Tel: 088 – 0187000 www.nil.nl
	135		Visueel en maten	
	Schaal: niet op schaal		Getekend: Examencomm. HVO	
	Maateenheid: mm		Datum: 28 – 05 – 2014	
Max. werktijd: 15 min.		● = Kandidaat nr.		
Werkstuk nr. 364 – RVS	Niveau: MAG-2 – RVS	Benaming: PIJP- PLAATLASVERBINDING		Rev: Mei 2017
				A 4

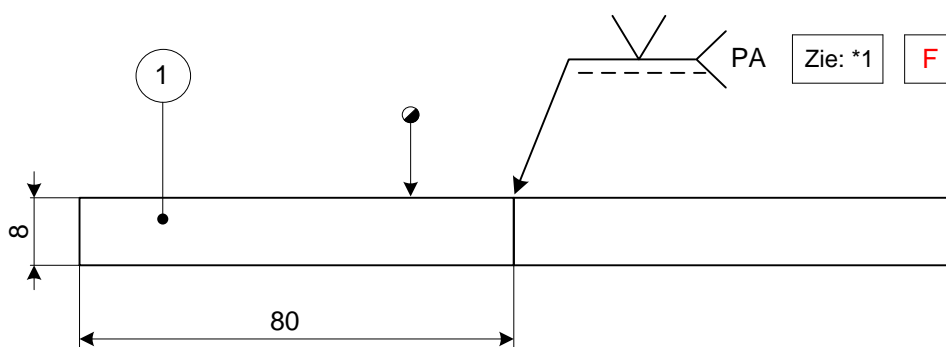
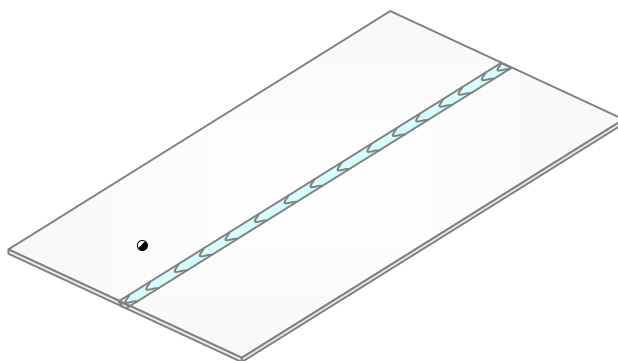

*1 = Doorlassing en backinggas vereist.

1	2	Plaat	80 x 8 – 250 (afschuining zijde 30°)	RVS 304 - 316
Stuk nr.	Aantal	Benaming	Afmetingen	Materiaalsoort
	Lasproces: 135		Beoordeling: Visueel en maten	Nederlands Instituut voor Lastechniek Tel: 088 – 0187000 www.nil.nl
	Schaal: niet op schaal		Getekend: Examencomm. HVO	
	Maateenheid: mm		Datum: 23 – 09 – 2014	
	Max. werktijd: 30 min.		● = Kandidaat nr.	
Werkstuk nr. 365 – RVS	Niveau: MAG-2 - RVS	Benaming: PLAAT- PLAATLASVERBINDING		Rev: Mei. 2017
				A 4