

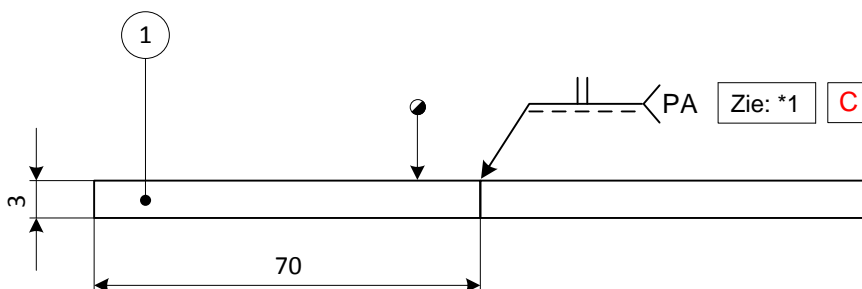

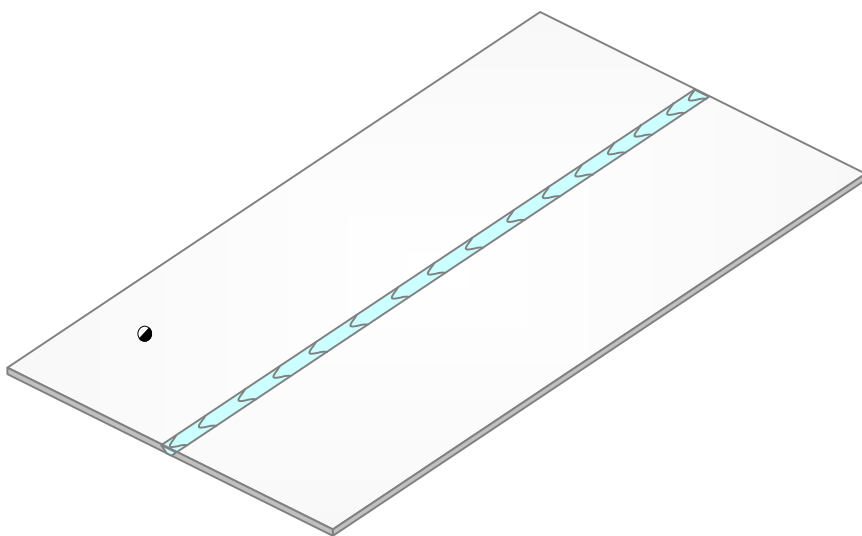

1	2	Plaat	70 x 3 – 250	RVS 304 – 316
Stuk nr.	Aantal	Benaming	Afmetingen	Materiaal­soort
	Lasproces:		Beoordeling:	Nederlands Instituut voor Lastechniek Tel: 088 – 0187000 www.nil.nl
	135-136		Visueel en maten	
	Schaal: niet op schaal		Getekend: Examencomm. HVO	
	Maateenheid: mm		Datum: 28 – 05 – 2014	
Max. werktijd: 20 min.		● = Kandidaat nr.		
Werkstuk nr. 350 - 351 – RVS	Niveau: MAG-1 - RVS	Benaming: OVERLAPLASVERBINDING		Rev: Mei. 2017
				A 4

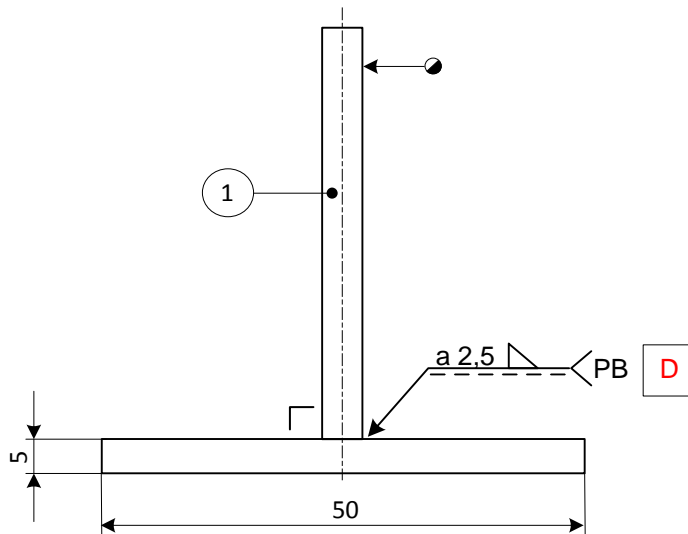
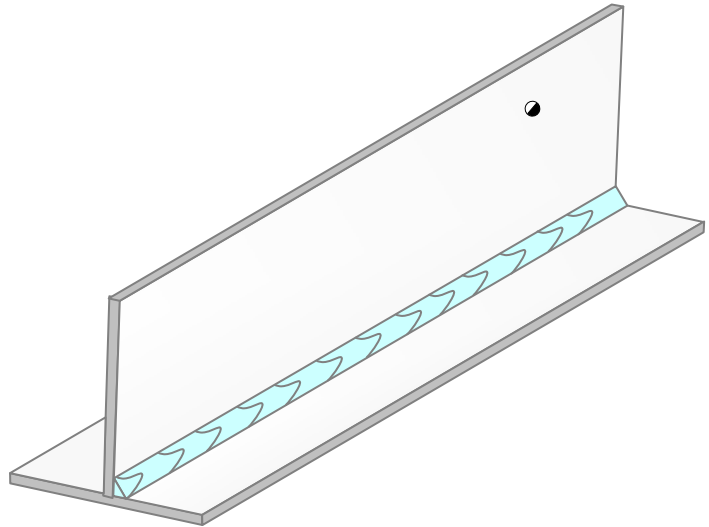

*1 = Doorlassing en backinggas vereist.

1	2	Plaat	70 x 3 – 250	RVS 304 - 316
Stuk nr.	Aantal	Benaming	Afmetingen	Materiaalsoort
	Lasproces:		Beoordeling:	Nederlands Instituut voor Lastechniek Tel: 088 – 0187000 www.nil.nl
	135		Visueel en maten	
	Schaal: niet op schaal		Getekend: Examencomm. HVO	
	Maateenheid: mm		Datum: 28 – 05 – 2014	
Max. werktijd: 20 min.		● = Kandidaat nr.		
Werkstuk nr. 352 – RVS	Niveau: MAG-1 - RVS	Benaming: PLAAT-PLAATLASVERBINDING		Rev: Mrt. 2017
				A 4



1	2	Plaat	50 x 5 – 250	RVS 304 - 316
Stuk nr.	Aantal	Benaming	Afmetingen	Materiaal­soort
	Lasproces:		Beoordeling:	Nederlands Instituut voor Lastechniek Tel: 088 – 0187000 www.nil.nl
	135		Visueel en maten	
	Schaal: niet op schaal		Getekend: Examencomm. HVO	
	Maateenheid: mm		Datum: 28 – 05 – 2014	
Max. werktijd: 20 min.		● = Kandidaat nr.		
Werkstuk nr. 353 – RVS	Niveau: MAG-1 - RVS	Benaming: BINNENHOEK­LAS­VER­BINDING		Rev: Mei. 2017
				A 4

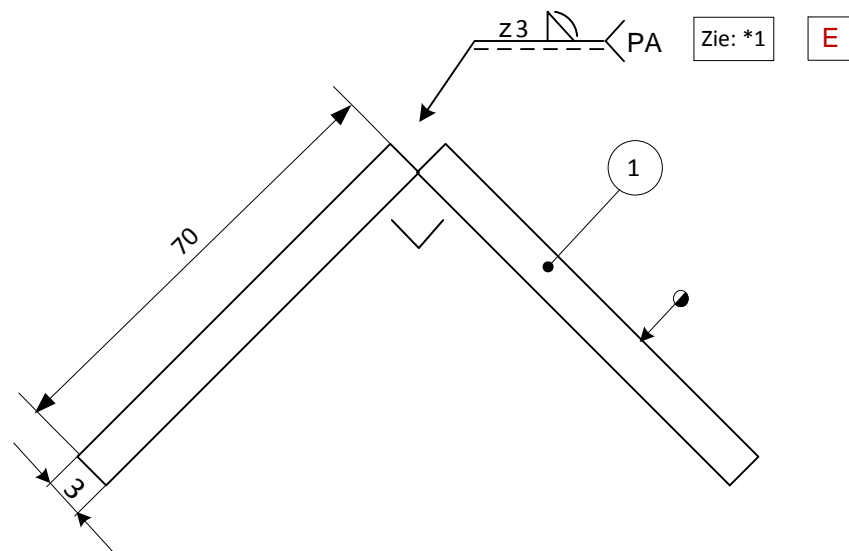
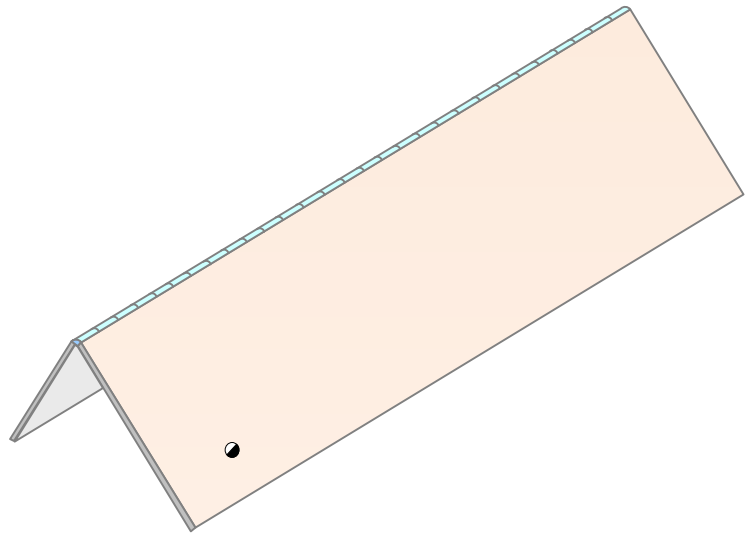

*1 = Doorlassing en backinggas vereist.

1	2	Plaat	70 x 3 – 250	RVS 304 - 316
Stuk nr.	Aantal	Benaming	Afmetingen	Materiaal­soort
	Lasproces:		Beoordeling:	Nederlands Instituut voor Lastechniek Tel: 088 – 0187000 www. nil.nl
	135		Visueel en maten	
	Schaal: niet op schaal		Getekend: Examencomm. HVO	
	Maateenheid: mm		Datum: 28 – 05 – 2014	
	Max. werktijd: 20 min.		● = Kandidaat nr.	
Werkstuk nr. 354 – RVS	Niveau: MAG-1 - RVS	Benaming: BUITENHOEK­LAS­VER­BIN­DING		Rev: Mei. 2017
				A 4

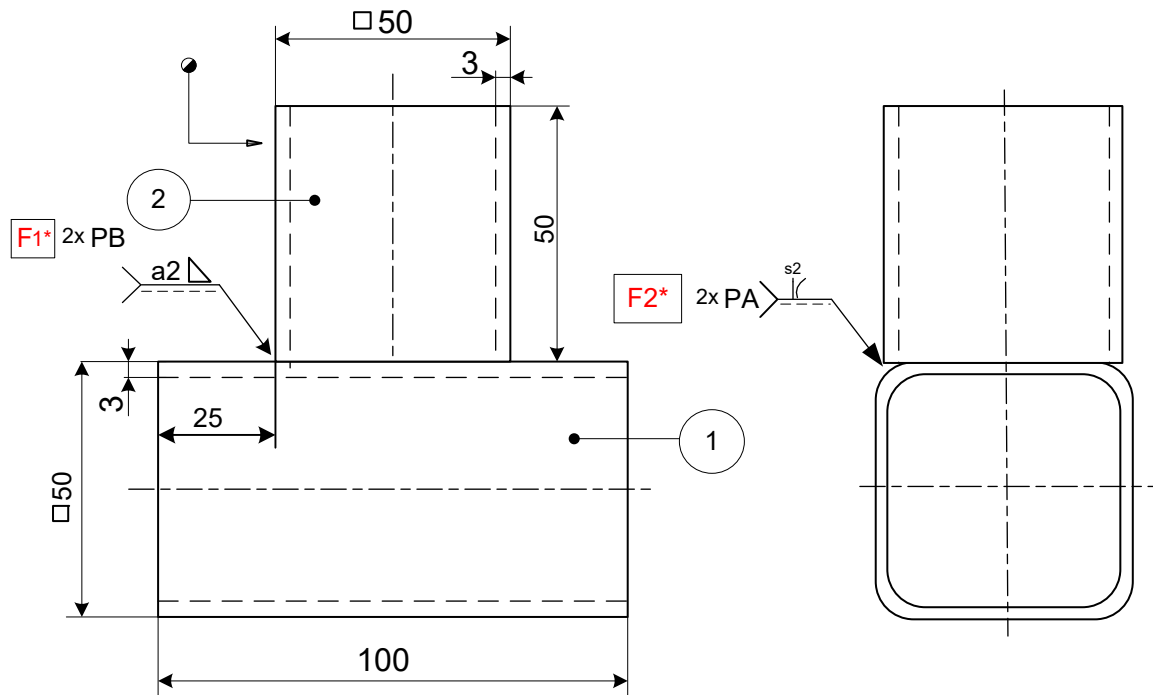
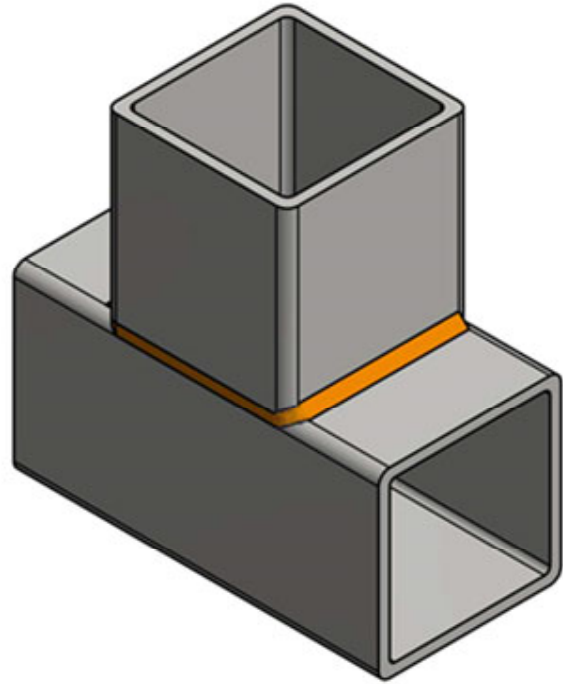

* Lassen F1 en F2 dienen vloeiend in elkaar over te lopen

2	1	Koker	50 x 50 x 3 – 50	RVS 304 - 316
1	1	Koker	50 x 50 x 3 – 100	RVS 304 - 316
Stuk nr.	Aantal	Benaming	Afmetingen	Materiaal­soort
	Lasproces:		Beoordeling:	Nederlands Instituut voor Lastechniek Tel: 088 – 0187000 www.nil.nl
	135		Visueel en maten	
	Schaal: niet op schaal		Getekend: Examencomm. HVO	
	Maateenheid: mm		Datum: 23 – 09 – 2014	
Max. werktijd: 20 min.		● = Kandidaat nr.		
Werkstuk nr. 355 – RVS	Niveau: MAG-1 - RVS	Benaming: KOKER – KOKERLASVERBINDING		Rev: Sept. 2020
				A 4